



## CHARACTERISTICS:

- Balanced.
- Multispring.
- Not dependent on the rotation direction.
- Barrier fluid connections.

## OPERATING LIMITS:

$$d_1 = 25 \div 100 \text{ mm} \quad p = 25 \text{ kg/cm}^2$$

$$v = 16 \text{ m/s} \quad t = -15 \div +200^\circ\text{C} (*)$$

(\*) The temperature resistance depends on the material of the secondary seals used.

The operating limits are defined by the PV factor which is determined for the sealing system characteristics and those of the application.

## DESCRIPTION:

A double cartridge with a "face to face" arrangement which permits operation with barrier fluid in excessive pressure with respect to the working fluid ( $P_1 + 1.5 - 2 \text{ Kgr/cm}^2$ )

The sleeve includes a pumping ring that facilitate the barrier fluid movement. The connections of Liquid barrier IN and OUT have to be connected according the rotation direction.

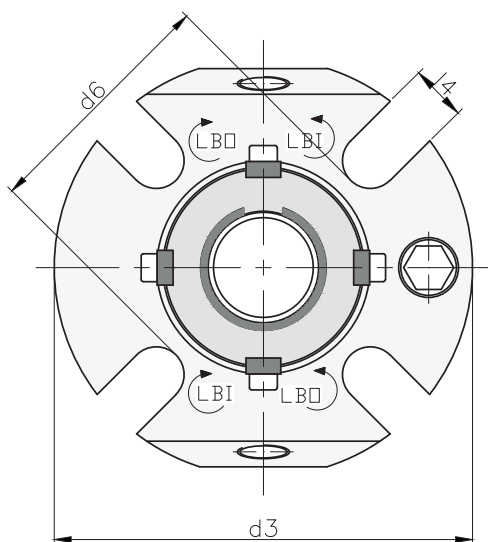

## CONNECTIONS (R):

From 25 mm to 35 mm: 1/4" NPT.  
From 38 mm to 100 mm: 3/8" NPT.

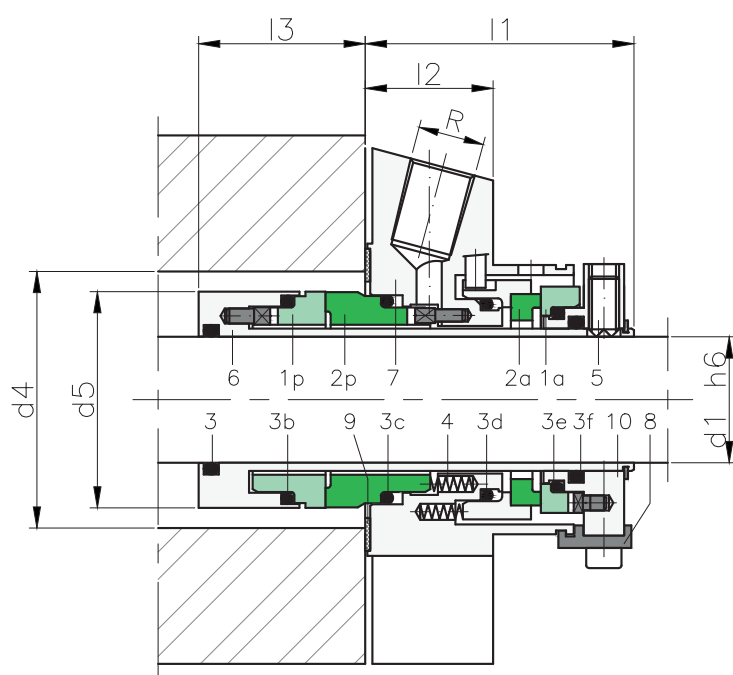

### COMPONENTS:

- 1p Rotating contact surface product side
- 2p Stationary contact surface product side
- 1a Stationary contact surface atmospheric side
- 2a Rotating contact surface atmospheric side
- 3 O-rings
- 4 Springs
- 5 Set screws
- 6 Sleeve
- 7 Flange
- 8 Setting clips
- 9 Flat gasket
- 10 Drive ring

## DIMENSIONS CHART

Dimensions in mm

Shaft										
mm	d <sub>3</sub>	d <sub>4</sub> min.	d <sub>4</sub> máx.	d <sub>5</sub>	d <sub>6</sub>	l <sub>1</sub>	l <sub>2</sub>	l <sub>3</sub>	l <sub>4</sub>	
25	105	44	51,5	43	62	53,4	25,4	33,1	13,2	
28	105	47	52	46	62	53,4	25,4	33,1	13,2	
30	105	49	56	48	67	53,4	25,4	33,1	13,2	
32	110	51	57	49,8	70	53,4	25,4	33,1	13,2	
33	110	51	57	49,8	70	53,4	25,4	33,1	13,2	
35	113	54	61,5	53	72	53,4	25,4	33,1	13,2	
38	123	57	66	56	75	53,4	25,4	33,1	13,2	
40	123	59	68	58	77	53,4	25,4	33,1	14,2	
42	133	61,5	69,5	60,5	80	53,4	25,4	33,1	14,2	
43	133	61,5	70,5	60,5	80	53,4	25,4	33,1	14,2	
45	138	64	73	62,5	82	53,4	25,4	33,1	14,2	
48	138	67	75	65,6	85	53,4	25,4	33,1	14,2	
50	148	69	78	68	87	53,4	25,4	33,1	14,2	
53	148	73	87	72	97	53,4	25,4	33,1	18	
55	148	74	83	73	92	53,4	25,4	33,1	18	
60	157	79	91	78	102	53,4	25,4	33,1	18	
65	163	85,7	98,5	84,8	109	53,4	25,4	33,1	18	
70	178	95	108	93	118	53,4	25,4	33,1	18	
75	190	101,6	118	100	129	63,9	28	44,1	18	
80	195	108	124	106,4	135	63,9	28	44,1	18	
85	198	111,1	128	109,5	139	63,9	28	44,1	22	
90	205	117,5	135	115,9	145	63,9	28	44,1	22	
95	208	120,7	138	119,1	148	63,9	28	44,1	22	
100	218	127	144	125,4	154	63,9	28	44,1	22	

Dimensions in inches

Shaft										
(")	mm	d <sub>3</sub>	d <sub>4</sub> min	d <sub>4</sub> máx	d <sub>5</sub>	d <sub>6</sub>	l <sub>1</sub>	l <sub>2</sub>	l <sub>3</sub>	l <sub>4</sub>
1,000	25,4	105,0	44,0	51,0	43,0	62,0	53,4	25,4	33,1	13,2
1,125	28,6	105,0	47,6	52,1	46,0	61,0	53,4	25,4	33,1	13,2
1,250	31,8	110,0	51,0	57,0	49,8	70,1	53,4	25,4	33,1	13,2
1,375	34,9	113,0	56,3	61,5	53,0	72,1	53,4	25,4	33,1	13,2
1,500	38,1	123,0	57,0	66,0	56,0	74,9	53,4	25,4	33,1	13,2
1,625	41,3	123,0	60,3	68,6	59,5	78,5	53,4	25,4	33,1	14,2
1,750	44,5	138,0	64,0	73,0	62,5	82,0	53,4	25,4	33,1	14,2
1,875	47,6	138,0	67,0	75,0	65,6	85,1	53,4	25,4	33,1	14,2
2,000	50,8	148,0	69,0	78,0	68,0	87,1	53,4	25,4	33,1	14,2
2,125	54,0	148,0	73,0	87,0	72,0	97,0	53,4	25,4	33,1	18,0
2,250	57,2	157,0	76,2	90,4	75,2	100,1	53,4	25,4	33,1	18,0
2,375	60,3	157,0	79,4	91,0	78,0	102,1	53,4	25,4	33,1	18,0
2,500	63,5	163,0	83,8	96,5	81,6	106,2	53,4	25,4	33,1	18,0
2,625	66,7	163,0	85,7	100,0	84,8	109,3	53,4	25,4	33,1	18,0
2,750	69,9	178,0	95,0	108,0	93,0	118,4	53,4	25,4	33,1	18,0
2,875	73,0	190,0	101,6	118,0	100,0	129,0	108,0	25,4	44,1	18,0
3,000	76,2	190,0	101,6	118,0	100,0	129,0	108,0	28,0	44,1	18,0
3,125	79,4	195,0	108,0	124,0	106,4	135,0	108,0	28,0	44,1	18,0
3,250	82,6	195,0	108,0	124,0	106,4	135,0	108,0	28,0	44,1	18,0
3,375	85,7	198,0	111,1	128,0	109,5	139,0	108,0	28,0	44,1	22,0
3,500	88,9	198,0	114,3	140,1	112,7	142,0	108,0	28,0	44,1	22,0
3,625	92,1	205,0	117,5	135,0	115,9	145,0	108,0	28,0	44,1	22,0
3,750	95,3	208,0	120,7	138,0	119,1	148,0	108,0	28,0	44,1	22,0
4,000	101,6	218,0	127,0	144,0	125,4	154,0	108,0	28,0	44,1	22,0

Dimensions subject to changes or modifications.